

PUNATSANGCHHU-I HYDROELECTRIC PROJECT AUTHORITY BHUTAN (PHPA-I)



BIDDING DOCUMENT

FOR

REPAIR & MAINTENANCE OF RAW WATER SUPPLY PIPELINE FROM NAHI TO BJIMTHANGKHA

(NIT No. PHPA-I/CE(C&P)/146-04/2023)

JUNE, 2023



**PUNATSANGCHHU-I HYDROELECTRIC PROJECT AUTHORITY (PHPA-I)
BHUTAN**

**NOTICE INVITING TENDER
NIT No. PHPA-I/CE(C&P)/146-04/2023**

Sealed item rate bids are hereby invited for and on behalf of Punatsangchhu-I Hydroelectric Project Authority (PHPA-I) from a reputed, experienced, and financially sound Bhutanese firm fulfilling the eligibility qualification requirements specified in the Bidding Documents for the work **“Repair & Maintenance of Raw Water Supply Pipelines from Nahi to Bjimthangkha, PHPA-I”**.

1 ELIGIBLE CRITERIA

The participating bidders shall be reputed, experienced, and financially sound Bhutanese fulfilling the followings:

- 1.1 Have an annual turnover of Nu/Rs. 1.5 Million or more of any 3 years of the last 5 years preceding the last date of bid submission.
- 1.2 Have a valid trade license and registered with CDB as **Small Class (W3)**.
- 1.3 Have the latest income tax/corporate tax clearance certificates. If such a clearance certificate is not being issued by the concerned authority, an authenticated photocopy of the latest income tax return shall be submitted by the Bidders.
- 1.4 Bidders should have experience in having completed similar works during the last 5 years of value Nu./Rs. **1.5 million or more**, and submit at least one Completion Certificate issued by the previous client(s). The Certificate shall indicate the value, date, and site of works and specify whether they were successfully completed.

The prospective bidders may download the Bidding Document from the PHPA-I website: www.phpa1.gov.bt from 26/06/2023 to 25/07/2023.

The PHPA-I reserves the right to reject any or all the Bids without assigning any reason thereof.

Executive Engineer (Contracts)



TERMS AND CONDITIONS OF THE WORK

1	SCOPE OF WORK.....	1
2	SPECIFICATIONS OF THE WORK.....	1
3	ELIGIBLE CRITERIA	1
4	DOCUMENT COMPRISING THE BID	1
5	BID SECURITY (EMD).....	2
6	BID VALIDITY.....	2
7	SITE VISIT	2
8	LANGUAGE OF BID.....	2
9	BID PRICE	2
10	SUBMISSION AND OPENING OF BIDS	2
11	EVALUATION AND COMPARISON OF THE BIDS.....	2
12	CORRECTION OF ERRORS	2
13	RIGHT OF ACCEPTANCE	3
14	AWARD OF CONTRACT	3
15	PERFORMANCE SECURITY	3
16	SIGNING OF CONTRACT AGREEMENT	3
17	COMMENCEMENT OF WORK	3
18	TIME FOR COMPLETION	3
19	EXTENSION OF TIME FOR COMPLETION	3
20	FORCE MAJEURE.....	4
21	LIQUIDATED DAMAGES FOR DELAY.....	4
22	MEASUREMENT.....	4
23	CERTIFICATES AND PAYMENT	4
24	RETENTION MONEY.....	5
25	VARIATIONS.....	5
26	DETERMINATION OF PRICE VARIATION	6
27	CERTIFICATION OF COMPLETION OF WORK	7
28	DEFECT LIABILITY/MAINTENANCE PERIOD.....	7
29	MAINTENANCE CERTIFICATE	7
30	TERMINATION OF THE CONTRACT	7
31	PAYMENT AFTER TERMINATION	7
32	COMPLIANCE WITH TAX LAWS.....	8



33	CONTRACTOR'S RISKS.....	8
34	LABOUR LAWS	8
35	PRE-CONTRACT INTEGRITY PACT	8
36	ENGINEER-IN-CHARGE.....	8
37	ARBITRATION.....	8



TERMS AND CONDITIONS OF THE CONTRACT

1 SCOPE OF WORK

- 1.1 The broad scope of works shall be **“Repair & Maintenance of Raw Water Supply Pipelines from Nahi to Bjimthangkha”** which shall include, but not be limited to the followings:
- 1.1.1 Clearing and grubbing, excavation in soil and rock, backfilling, Centering/Shuttering, Plain Cement Concrete, Reinforced Cement Concrete, Gabion wall, and
 - 1.1.2 other miscellaneous works to fulfill the functional requirements as per the drawings, Specifications, Bill of Quantities and/or as directed by the Engineer-in-Charge.

2 SPECIFICATIONS OF THE WORK

- 2.1 The specifications, the materials used and the Work done shall conform to the relevant Specifications for Building and Road Works (BSR): Royal Govt. of Bhutan, 2022/I.S. Code or as directed by the Engineer-in-Charge. The Contractor shall endeavor to provide all such necessary efforts in order to comply with the intent of these specifications to the satisfaction of the Engineer-in-Charge.
- 2.2 The BSR specifications outline the standard of materials, the technical procedure to conduct work including tests and quality checks, the mode of measurement, and the applicability of rates for the items of work in BoQ. Reference to relevant codes may be made wherever required or necessary.

3 ELIGIBLE CRITERIA

- 3.1 The participating bidders shall be reputed, experienced, and financially sound Bhutanese fulfilling the followings:
- 3.1.1 Have an annual turnover of Nu./Rs. 1.5 Million or more of any 3 years of the last 5 years preceding the last date of bid submission.
 - 3.1.2 Have a valid trade license and registered with CDB as *Small Class (W3)*.
 - 3.1.3 Have the latest income tax/corporate tax clearance certificates. If such a clearance certificate is not being issued by the concerned authority, an authenticated photocopy of the latest income tax return shall be submitted by the Bidders.
 - 3.1.4 Bidders should have experience in having completed similar works during the last 5 years of value Nu./Rs. 1.5 million or more, and submit at least one Completion Certificate issued by the previous client(s). The Certificate shall indicate the value, date, and site of works, and shall specify whether they were successfully completed.

4 DOCUMENT COMPRISING THE BID

- 4.1 The Bid shall include the following documents:
- 4.1.1 Bid Security
 - 4.1.2 Valid Trade License
 - 4.1.3 CDB Registration Certificate
 - 4.1.4 Latest tax clearance Certificate



4.1.5 Duly filled Bill of Quantities

4.1.6 Complete Bidding Document, duly signed by the bidder as its acceptance.

5 BID SECURITY (EMD)

- 5.1 Bidder shall furnish Bid Security for an amount of **Nu. 30,000/-** along with their bid, failing which bids will be rejected. Bid Security shall remain valid for **30** days beyond the validity of the Bid.
- 5.2 Bid Security shall be in any form: A Demand Draft or irrevocable Bank Guarantee issued by Banks of Bhutan, payable to Punatsangchhu-I Hydroelectric Project Authority.
- 5.3 Bid Security is liable to be forfeited if the bidder withdraws or amends within the period of bid validity or the successful bidder fails to sign the contract agreement.
- 5.4 The Bid Security of the successful bidder shall be returned after receipt of the Performance Security and signing of the Contract Agreement.
- 5.5 Bid Security of unsuccessful bidders shall be returned within 28 days of the signing of the contract with the successful bidder.

6 BID VALIDITY

A bid shall remain valid for **90 days** from the date of its opening.

7 SITE VISIT

The bidders are advised to visit the site, its surroundings and obtain all information that may be necessary for preparing a bid. The cost of visiting the site shall be at the bidder's own expense.

8 LANGUAGE OF BID

The bid and all correspondence related to this tender shall be in English.

9 BID PRICE

Bidders shall quote rates for all items in the Bill of Quantities (BoQ) which shall be inclusive of taxes. The rate shall remain firm and shall not be subjected to any adjustment during the performance of the contract.

10 SUBMISSION AND OPENING OF BIDS

Bid must be received by the Executive Engineer, Contracts, PHPA-I, Bjimthangkha on or before 1300 hours of **25.07.2023** and shall be opened on the same day at 1500 Hours. Late bids shall be rejected.

11 EVALUATION AND COMPARISON OF THE BIDS

- 11.1 The bids will be evaluated & compared by the PHPA-I from the technical & financial points of view so as to make a selection for the complete Work covered under the bidding documents.
- 11.2 Price bids of only techno-commercially responsive Bidders will be evaluated by the PHPA-I.

12 CORRECTION OF ERRORS

12.1 Any arithmetic errors in Price Bids shall be corrected by the PHPA-I as follow:

- 12.1.1 Where there is a discrepancy between the rate in figure and in words, the rate in words will govern; and



12.1.2 Where there is a discrepancy between the unit rate and the total amount derived from multiplying the unit rate and the quantity, the unit rate as quoted will govern and the total amount shall be corrected.

12.1.3 If the bidder does not accept the corrected amount of the bid, his bid will be rejected and the bid security will be forfeited.

13 RIGHT OF ACCEPTANCE

13.1 PHPA-I is not bound to accept the lowest bid and reserves the right to accept or reject any or all bids without assigning any reason thereof.

13.2 If PHPA-I decides to accept the abnormally low (20% below the estimate) bids after considering the detailed price analysis, PHPA-I may as appropriate:

13.2.1 may ask the successful bidder to deposit the differential amount between the departmental estimate and quoted amount in the form of a cash warrant/demand draft/BG

14 AWARD OF CONTRACT

PHPA-I will issue a Letter of Award (LoA) to the successful bidder before the expiration of the Bid validity.

15 PERFORMANCE SECURITY

15.1 Within 15 days of issuance of Letter of Award by PHPA-I, the successful bidder shall furnish Performance Security in the form of an irrevocable Bank Guarantee on the Proforma provided by PHPA-I (**Form-3**) for an amount equivalent to **10%** of the Contract Price.

15.2 The Performance Security shall be valid up to 30 days from the date of issue of the Completion Certificate.

16 SIGNING OF CONTRACT AGREEMENT

Within 30 days of issuance of the Letter of Award and after submission of Performance Security, on a date and time mutually agreed upon, the successful bidder or his authorized representative shall sign the Contract with PHPA-I.

17 COMMENCEMENT OF WORK

The work shall be commenced within 30 days from the date of issue of the Letter of Award.

18 TIME FOR COMPLETION

The works shall be completed in all respect within **6 months** or such extended time as may be allowed under clause 19. The period of completion shall be reckoned from the 30th day of issue of the Letter of Award.

19 EXTENSION OF TIME FOR COMPLETION

Should the amount of extra or additional work of any kind may or any cause of delay referred to in these conditions, or other special circumstances of any kind whatsoever which may occur, other than through the default of the Contractor, be such as fairly to entitle the Contractor to an extension of time for the completion of Work, the Engineer-in-Charge shall determine the period



from the Hindrance Register to be maintained by the Contractor of such extension and shall notify the Contractor accordingly.

20 FORCE MAJEURE

- 20.1 “Force Majeure” means any circumstances beyond the control of the parties i.e., the PPHA-I & the contractor including but not limited to acts of PPHA-I in its sovereign capacity, wars or revolution, pandemic or epidemic, fire, floods, earthquake affecting the contractor’s work, except where solely restricted to employees of the contractor or his sub-contractor and freight embargoes.
- 20.2 If a Force Majeure situation arises, the Contractor shall promptly notify PPHA-I in writing of such condition and the cause thereof. Unless otherwise directed by the PPHA-I in writing, the Contractor shall continue to perform his obligations under the Contract as far as is reasonably practical, and shall seek all reasonable alternative means for performance not prevented by the Force Majeure event.

21 LIQUIDATED DAMAGES FOR DELAY

If the Contractor fails to complete the Work within the time prescribed by Clause 18, the Liquidated Damages at the rate of **0.1%** per day shall be imposed subject to a maximum of **10%** of the Final Executed Amount.

22 MEASUREMENT

All measurements shall be taken jointly by the Engineer-in-Charge and the Contractor from time to time during the progress of the work, and such measurements shall be signed by the parties as a token of acceptance.

23 CERTIFICATES AND PAYMENT

23.1 Interim Payment Certificate

- 23.1.1 The contractor shall submit an application for interim payment, in duplicate, to the Engineer-In-Charge.
- 23.1.2 No interim Payment certificate shall be issued for a sum less than **3%** of the Contract Price.
- 23.1.3 It may be noted that all the interim payments shall be treated as provisional payments.

23.2 Mobilization advance

- 23.2.1 An advance to the extent of **10% of the Contract Price**, if required by the contractor, will be granted for mobilization of labour, stores, and workshops including camps, labour sheds, and constructional plants.
- 23.2.2 The advance will be disbursed on production of the irrevocable Bank Guarantee (on the Proforma in **Form-4**) from any Financial Institution of Bhutan for an amount equivalent to the required advance and the BG shall valid till the advance is fully recovered.
- 23.2.3 The advance shall be free of interest
- 23.2.4 The advance is recoverable and the deduction of the advance shall be made on prorate percentage basis from the interim payment certified by the Engineer-in-Charge.



23.2.5 The entire amount of the advance paid to the Contractor shall be fully deducted by the time the total of all payments to the Contractor has reached 80% of the contract price.

23.3 Final certificate

23.3.1 Since all the interim payment certificates are issued provisionally, EIC may, by any interim payment certificate, make any corrections or modifications in any previous certificate (other than one purporting to be the final payment certificate) which shall have been issued by him and shall have the power to modify or withhold any interim certificate if the works or any part thereof are not being carried out to his satisfaction.

23.3.2 On receipt of the final bill, the EIC shall promptly prepare and issue to the contractor a final payment certificate certifying any further money due to the contractor in respect of the contract. Payment to the contractor of the amount due under the final payment certificate shall be made by PHPA-I within 60 days of such certificate being issued. In the event of non-payment within the said period, no interest shall accrue to the contractor.

24 RETENTION MONEY

24.1 The Employer shall retain 10% from each payment due to the Contractor until completion of the whole of the Work.

24.2 The retention money shall be released to the Contractor within 21 days from the date of issue of the Maintenance Certificate.

25 VARIATIONS

25.1 The Engineer-in-Charge shall make any variation in the form, quality, or quantity of the Works or any part thereof or substitution for original specifications, design, drawings, and instructions that may, in his opinion be necessary and for that purpose, or if for any other reason it shall, in his opinion be appropriate, he shall have the power to order the Contractor to do and the Contractor shall do any or all of the following:

25.1.1 increase or decrease the quantity of any work included in the Contract;

25.1.2 omit or substitute any such work;

25.1.3 change the character or quality or kind of any such work;

25.1.4 change the levels, lines, positions, and dimensions of any part of the work;

25.1.5 execute, additional work of any kind necessary for the completion of the works, and

25.1.6 change any specified sequence or timing of construction of any part of the work.

25.2 No such variations shall in any way vitiate or invalidate the Contract, but the effect if any, of all such variations, shall be valued in accordance with Clause-26 hereof.

25.3 Provided that where the issue of an instruction to vary the Works is necessitated by some default of or breach of Contract by the Contractor or for which he is responsible, any additional cost attributable to such default shall be borne by the Contractor. Any altered, additional, and substituted work which the Contractor may be directed to do in the manner above specified as part of the Works, shall be carried out by the Contractor on the same conditions in all respects on which he agreed to do the main Works.



26 DETERMINATION OF PRICE VARIATION

- 26.1 Upon certified completion of the whole Works, if a reduction or increase in the total value of the work is found to be within 20% of the initial Contract price, then there shall be no change in the Contract rates for individual items of work specified in the bill of quantities irrespective of the quantum of variation in individual items.
- 26.2 However, if a reduction or increase is found to be more than 20% of the initial Contract price, the increase in payment for minus variation or decrease in payment for plus variation shall be specified based on slabs of variation in the Contract value as specified below:

Variation in Value of Works	Increase in Payment for minus variation	Decrease in Payment for plus variation
Up to 20%	Nil	Nil
Above 20% and up to 35 %	6.00%	3.00%
Above 35% and up to 60%	8.00%	4.00%
Above 60 % and up to 100%	10.00%	5.00%
Above 100%	NA	5.00%

- 26.3 While working out the value of Works for the purpose of variation, the extra items for which new rates have been paid and payment towards price adjustment; and the adjustment towards statutory variations shall not be considered.

26.4 Illustration

- 26.4.1 In case of variation in the value of Works by (plus) + 60 percent, the payment for (60-20) percent i.e., 40 percent of the Contract value of Works shall be decreased by 4 % (four percent.). The reduction in Contract rates shall commence as soon as the value of the Works executed reaches 120% of the Contract Price.
- 26.4.2 In case of variation in the value of Works by (minus) – 55 percent, the payment for (55-20) percent i.e., 35 percent of the Contract value of Works shall be increased by 8% (eight percent).
- 26.5 No variation limit for any individual BOQ item has been specified except for the payment due to the Contractor as detailed above. No claim for revision of rate(s) for any individual BOQ item shall be admissible irrespective of the extent to which the ordered quantity may get revised (+) or (-) during the actual execution of the Works.
- 26.6 Within 14 days of the date of instruction for executing varied Works and before the commencement of such Works, notice shall be given either (a) by the Contractor to the Employer of his intention to claim extra payment or a varied rate or price, or (b) by the Engineer-in-Charge to the Contractor of the intention to vary a rate or price.
- 26.7 The Contractor within 14 days from the receipt of an order to execute any extra item shall submit rate analysis to the Engineer-in-Charge supported by documentary evidence of basic rates adopted therein; having regard to the cost of materials, actual wages of labor, and other operational costs. The analysis so provided by the Contractor shall form the basis for the determination of rates for such extra items. Extra items of work/supply which are not provided in the Bill of Quantities shall be paid on the basis of the Bhutan Schedule of Rates (BSR) after adjusting such rates for the place of Works and cost index prevailing at the time



of the award. If rates for such extra items are not available in BSR, the rates for such items shall be determined based on the actual expenditure relating to that item including the cost of materials, fabrication/machinery handling, and erection at the Site plus twenty percent (20%) towards overheads including profits. The price of varied items determined by the Engineer-in-Charge shall be final and binding on the Contractor. No payment shall be made for the items of Works ordered to be omitted.

26.8 If there is a delay in the agreement between the Employer and the Contractor on the rate of varied Works, provisional rates @ 75% of the rates as determined by the Engineer In-charge shall be payable as a provisional payment till such time as the rates are finalized.

26.9 Under no circumstances, the Contractor shall at any stage suspend work on account of non-settlement of rates of such item(s).

27 CERTIFICATION OF COMPLETION OF WORK

When the whole of the Work has been completed, the Contractor may give notice to the Engineer-in-Charge. The Engineer-in-Charge shall, within 21 days from the date of delivery of such notice, issue a Certificate of Completion stating the date on which the Work is completed in accordance with the contract.

28 DEFECT LIABILITY/MAINTENANCE PERIOD

28.1 The Defect Liability/Maintenance Period shall be **6 months** from the date of issue of the Completion certificate.

28.2 All repair works shall be carried out by the Contractor at his own expense if the necessity shall be due to the use of materials or workmanship not in accordance with the contract or due to negligence or failure on the part of the Contractor to comply with any obligation, expressed or implied.

28.3 If the Contractor fails to do any such work aforesaid, PHPA-I shall arrange to carry out the same, and payment shall be recovered from the Contractor's due money.

29 MAINTENANCE CERTIFICATE

29.1 The Contract shall not be considered complete until a Maintenance Certificate shall have been issued by the EIC stating that the works have been completed and maintained to his satisfaction

29.2 The Maintenance Certificate shall be issued by the EIC within **28 days** after the expiry of the period of maintenance.

30 TERMINATION OF THE CONTRACT

30.1 The Contract can be terminated at any time by either party by serving **14 days** prior notice in writing if the other party causes any fundamental breach of the contract.

30.2 Notwithstanding the above, PHPA-I may terminate the contract for convenience.

31 PAYMENT AFTER TERMINATION

31.1 If the Contract is terminated because of a fundamental breach of Contract by the Contractor, the EIC shall issue a certificate for the value of the work done and materials ordered less advance payments received up to the date of the issue of the Certificate and **20%** less the



percentage to apply to the value of work not completed. If the total amount due to the PHPA-I exceeds any payment due to the Contractor, the difference shall be a debt payable by the Contractor to PHPA-I.

- 31.2 If the Contract is terminated for PHPA-I's convenience or because of the fundamental breach of Contract by the PHPA-I, the EIC shall issue a certificate for the value of work done, materials ordered, the reasonable cost of removing the equipment, repatriation of the Contractors personal employed solely on this work, and the contractor's cost of protecting and securing the work, and less advance payments received up to the date of the certificate.

32 COMPLIANCE WITH TAX LAWS

- 32.1 Any Contractor, or sub-contractor recruited in connection with the Work will be liable for tax in Bhutan as per the Income Tax Act of the Kingdom of Bhutan, 2001. Further, such recruiting agency shall be responsible for deducting and remitting Tax Deducted at Source (TDS) as per the provision of the said Income Tax Act.

- 32.2 Contractor Tax of 2% shall be deducted from every bill of the Contractor.

33 CONTRACTOR'S RISKS

From the Start Date until the end of the Defect Liability period, the risks of personal injury, death, and loss of or damage to property (including, without limitation, the Work, Materials, and Equipment) are the liabilities of the Contractor.

34 LABOUR LAWS

The Contractor shall comply with all relevant labour laws/Acts of Bhutan applicable to the Contractor's Personnel, including Laws relating to their employment (including wages and working hours), health, safety, and welfare.

35 PRE-CONTRACT INTEGRITY PACT

As per the norms of the Anti-Corruption Commission, the Constitutional body of the Royal Government of Bhutan, the Contractor shall have to sign a Pre-Contract Integrity Pact as per format enclosed as *Form-I*.

36 ENGINEER-IN-CHARGE

EE (CIMD) shall be Engineer-in-Charge of this Work.

37 ARBITRATION

Any dispute, unless settled amicably, shall be settled in accordance with the Alternative Dispute Resolution Act of Bhutan, 2013.



EE, Contracts.

Pre-Contract Integrity Pact.

Note: This Proforma is included in the Bidding Documents for information of Bidders and shall be signed by the successful Bidder when the work(s) is awarded. Signing authorities will be the head of the client (agency) or the authorized representative of the bidder.

1. General:

Whereas the Punatsangchhu-I Hydroelectric Project Authority (PHPA-I) hereinafter referred to as the "Employer" on one part, and(Name of bidder or his/her authorized representative, with power of attorney) representing M/s., (Name of firm), hereinafter referred to as the "Bidder" on the other part hereby execute this agreement as follows:

This agreement shall be a part of the standard bidding document, which shall be signed by both parties at the time of purchase of bidding documents and submitted along with the tender document. This IP is applicable only to "large" scale works, goods and services, the threshold of which will be announced by the government from time to time. The signing of the IP shall not apply to framework Contracting such as annual office supplies etc.

2. Objectives:

Whereas, the Employer and the Bidder agree to enter into this agreement, hereinafter referred to as IP, to avoid all forms of corruption or deceptive practice by following a system that is fair, transparent and free from any influence/unprejudiced dealings in the Bidding process and Contract Administration, with a view to:

- 2.1 Enabling the Employer to obtain the desired Contract at a reasonable and competitive price in conformity to the defined specifications of the works or goods or services; and
- 2.2 Enabling bidders to abstain from bribing or any corrupt practice in order to secure the Contract by providing assurance to them that their competitors will also refrain from bribing and other corrupt practices.

3. Scope:

The validity of this IP shall cover the bidding process and Contract Administration period.

4. Commitments of the Employer:

The Employer Commits itself to the following: -

- 4.1 The Employer hereby undertakes that no officials of the Employer, connected directly or indirectly with the Contract, will demand, take a promise for or accept, directly or through intermediaries, any bribe, consideration, gift, reward, favor or any material or immaterial benefit or any other advantage from the Bidder, either for themselves or for any person,



organization or third party related to the Contract in exchange for an advantage in the bidding process and Contract Administration.

- 4.2 The Employer further confirms that its officials shall not favor any prospective bidder in any form that could afford an undue advantage to that particular bidder in the bidding process and Contract Administration and will treat all Bidders alike.
- 4.3 Officials of the Employer, who may have observed or noticed or have reasonable suspicion shall report to the head of the employing agency or an appropriate government office any violation or attempted violation of clauses 4.1 and 4.2.
- 4.4 The Following report on violation of clauses 4.1 and 4.2 by the official(s), through any source, necessary disciplinary proceedings, or any other action as deemed fit, including criminal proceedings shall be initiated by the Employer and such a person shall be debarred from further dealings related to the bidding process and Contract Administration.

5. Commitments of Bidders

The Bidder commits himself/herself to take all measures necessary to prevent corrupt practices, unfair means and illegal activities during any stage of the bidding process and Contract administration in order to secure the Contract or in furtherance to secure it and in particular commits himself/herself to the followings:-

- 5.1 The Bidder shall not offer, directly or through intermediaries, any bribe, gift, consideration, reward, favor, any material or immaterial benefit or other advantages, commission, fees, brokerage or inducement to any official of the Employer, connected directly or indirectly with the bidding process and Contract Administration, or to any person, organization or third party related to the Contract in exchange for any advantage in the bidding process and Contract Administration.
- 5.2 The Bidder shall not collude with other parties interested in the Contract to manipulate in whatsoever form or manner, the bidding process, and Contract Administration.
- 5.3 If the bidder(s) have observed or noticed or have reasonable suspicion that the provisions of the IP have been violated by the procuring agency or other bidders, the bidder shall report such violations to the head of the procuring agency.

6. Sanctions for Violation:

The breach of any of the aforesaid provisions shall result in administrative charges or penal actions as per the relevant rules and laws.

- 6.1 The breach of the IP or commission of any offense (forgery, providing false information, misrepresentation, providing false/fake documents, bid rigging, bid steering, or coercion) by the Bidder, or anyone employed by him, or acting on his/her behalf (whether with or without the knowledge of the Bidder), shall be dealt with as per the terms and conditions of the Contract and other provisions of the relevant laws, including De-barment Rules.
- 6.2 The breach of the IP or commission of any offense by the officials of the procuring agency shall be dealt with as per the rules and laws of the land in vogue.



7. Monitoring and Administration:

- 7.1 The respective procuring agency shall be responsible for the administration and monitoring of the IP as per the relevant laws.
- 7.2 The bidder shall have the right to appeal as per the arbitration mechanism contained in the relevant rules.

We, hereby declare that we have read and understood the clauses of this agreement and shall abide by it.

The parties hereby sign this Integrity Pact at (place) _____ on (date) _____

EMPLOYER

BIDDER

Witness:

Witness:



Proforma for Bank Guarantee for Bid Security

To

The Punatsangchhu-I Hydroelectric Project Authority (PHPA-I)

(Address of PHPA-I)

WHEREAS, (Name of Bidder) _____ (hereinafter called “the BIDDER”) has submitted his bid dated (_____ for the construction of (Name of Contract) _____ (hereinafter called “the Bid”).

KNOW ALL MEN by these presents that we (Name of Bank) _____ of (Name of Country) _____ having our registered office at _____ (hereinafter called “the Bank”) are bound unto the Punatsangchhu-I Hydroelectric Project Authority (PHPA-I) in the sum of _____ for which payment well and truly to be made to the PHPA-I the Bank binds himself, his successors and assigns by these presents.

SEALED with the Common Seal of the said Bank this _____ day of _____.

1. THE CONDITIONS of this obligation are;

- 1.1 If the Bidder withdraws his Bid during the period of bid validity specified in the Proforma of Bid; or
- 1.2 If the Bidder has been notified of the acceptance of his Bid by the PHPA-I during the period of bid validity;
 - 1.2.1 fails or refuses to execute the Proforma of Agreement in accordance with the Instructions to Bidders, if required; or
 - 1.2.2 fails or refuses to furnish the Performance Security, in accordance with the Instructions to Bidders,

We undertake to pay to the PHPA-I up to the above amount upon receipt of its first written demand, provided that in its demand the PHPA-I will note that amount claimed by it is due to it owing to the occurrence of one or both of the two conditions, specifying the occurred condition or conditions.



This Guarantee shall remain valid for 120 days from the bid's opening date as stated in the Invitation to Bid or as extended by you at any time prior to this date, a notice of which extends the Bank is hereby waived, and any demand in respect thereof should reach the Bank not later than the above date.

DATE

SIGNATURE OF THE BANK

WITNESS

SEAL

(Signature, Name and Address)



Proforma for Bank Guarantee for Performance Security

To

The Punatsangchhu-I Hydroelectric Project Authority,

(Address of PHPA-I)

WHEREAS (Name and Address of Contractor) _____ (hereinafter called “the Contractor”) has undertaken, in pursuance of Contract No. _____ dated _____ to execute (Name of Contract and Brief Description of Works) _____ (hereinafter called “the Contract”).

AND WHEREAS it has been stipulated by you in the said Contract that the Contractor shall furnish you with a Bank Guarantee by a recognized bank for the sum specified therein as security for compliance with his obligations in accordance with the Contract;

AND WHEREAS we have agreed to give the Contractor such a Bank Guarantee;

NOW THEREFORE we hereby affirm that we are the Guarantor and responsible to you, on behalf of the Contractor, up to a total of Nu. _____ (Amount of Guarantee in words to be inserted by the Guarantor), representing the percentage of the Contract Price, specified in the Contract, and we undertake to pay you, upon your first written demand and without cavil or argument, any sum or sums within the limits of Nu. _____ (Amount of Guarantee) as aforesaid without your needing to prove or to show grounds or reasons for your demand for the sum specified therein.

We hereby waive the necessity of your demanding the said debt from the Contractor before presenting us with the demand.

We further agree that no change or addition to or other modification of the terms of the Contract or of the Works to be performed there under or of any of the Contract documents which may be made between you and the Contractor shall in any way release us from any liability under this guarantee, and we hereby waive notice of any such change, addition or modification.

This guarantee is valid until the date 30 days from the date of issue of the Completion Certificate.

SIGNATURE AND SEAL OF THE GUARANTOR

Name of Bank

Address

Date



Proforma for Bank Guarantee for Mobilization Advance

In consideration of the Punatsangchhu-I Hydroelectric Project Authority (PHPA-I) (which expression shall unless repugnant to the subject or context include its administrators, successors and assigns), (hereinafter called the "Principal") having agreed to make advance payment to (Name and full address of the Contractor) _____ (hereinafter called "the Contractor(s)", (which expression shall unless repugnant to the subject or context or meaning thereof include its successors, administrator, executors and permitted assigns), whose bid for (Name of the Contract) _____ has been accepted and to whom the acceptance of the bid has been communicated by a Letter of Award and who is required to execute a formal agreement on conditions of production of a Bank Guarantee for Rs..... (Both in figures and words) _____ we, the _____ Bank (any financial institutions in Bhutan) hereinafter referred to as "the Bank") do hereby undertake promise and guarantee payment to the Principal on demand all the amounts advanced by the Principal to the said Contractor.

1. The Bank further agrees that;
 - 1.1. The Principal shall have the fullest liberty without affecting in any way the liability of the Bank under the Guarantee or Indemnity, from time to time, to vary any of the terms and conditions of the said Contract or to extend time for performance by the said Contractor or to postpone for any time and from time to time any of the powers exercisable by it against the said Contractor and either to enforce or forbear from enforcing any of the terms and conditions governing the said Contract or the securities available to the Principal and the Bank shall not be released from its liability under these presents by any exercise by the Principal of the Liberty with reference to the matters aforesaid or by reason of time being given to the said Contractor or any other forbearance, act or omission on the part of the Principal or any indulgence by the Principal to the said Contractor or of any other matter or thing whatsoever which under the law relating to sureties would but for this provision have the effect of a releasing the Bank from its such liability.
 - 1.2. These presents shall be governed by and constructed in accordance with Bhutanese laws.
 - 1.3. The Bank hereby declares that it has the power to issue this Guarantee and the undersigned has full power to do so.
 - 1.4. It shall not be necessary for the Principal to proceed against the Contractor before proceeding against the Bank and the Guarantee herein contained shall be enforceable against the Bank, notwithstanding any other security which the Principal may have obtained or obtain from the Contractor, shall at the time when proceedings are taken against the Bank hereunder, be outstanding or unrealized.
 - 1.5. The Guarantee herein contained shall remain in full force and effect, during the period that would be taken for the performance of the terms and conditions of the said Contract, Letter of Award and the Agreement which is to be executed as aforesaid and that it shall continue to be enforceable until all the dues of the Principal have been duly paid and its claims satisfied and discharged and till the Principal discharges the Guarantee in writing or until _____ whichever is earlier.



2. The Bank lastly undertakes not to revoke this Guarantee until all the dues of the Principal have been duly paid except with the previous consent of the Principal in writing.

Dated the _____ Day of _____ 2021

Here affix the Common Seal of the
Bank for _____ Bank Ltd.

Note: The Bidders are not required to fill this Proforma.



Bill of Quantities for Repair and Maintenance of Raw Water Supply Pipelines from Nahi to Bjinthangkha

Item No	Description of Item	Unit	Qty	Rate		Amount (Nu.)
				In figure (Nu.)	In Word (Nu.)	
1	2	3	4	5	6	7
1	Earth work in excavation over areas, depth >300mm, width >1.5m, area >10 Sq.m on plan, including disposal of excavated earth within 50m lead and 1.5m lift & disposed soil to be neatly dressed - all types of soil	Cu.m	75.45			
2	Filling of trenches, sides of foundations etc. in layers <200mm using selected excavated earth, ramming etc. within lead 50 m & lift 1.5m	Cu.m	247.20			
3	Providing & fixing centering and shuttering (formwork), including strutting, propping etc. and removal of formwork- Foundation and plinth etc	Sq.m	82.74			
4	Providing & fixing Thermo-Mechanically Treated reinforcement bar (Yield Strength 500 MPa) for R.C.C work including cutting,bending ,binding and placing in position complete	Kg	587.80			
5	Providing & laying in position reinforced cement concrete excluding the cost of centering , shuttering and reinforcement - all work upto plinth level - 1:1.5:3 (1 cement : 1.5 sand : 3 graded crushed rock 20 mm nominal size)	Cu.m	7.97			
6	Providing and laying in position plain cement concrete excluding the cost of centering and shuttering - All work upto plinth level.- 1:1.5:3 (1 cement : 1.5 sand : 3 graded crushed rock 20 mm nominal size)	Cu.m	2.97			
7	Providing & filling hand-packed stone in G.I mesh 4mm (8swg)including supplying and weaving of mesh complete- Double-knotted mesh.....100mm	Cu.m	329.60			
Total (A)						

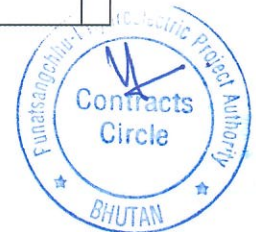

Item No	Description of Item	Unit	Qty	Rate		Amount (Nu.)
				In figure (Nu.)	In Word (Nu.)	
1	2	3	4	5	6	7
8	<p>Occupational Health and Safety (OHS)</p> <p>Incorporation of Occupational Health and Safety measures at construction sites as per the attached requirements list. The standards and specifications for the Insurance, OHS materials and (or) equipment shall be in compliance with the Labour and Employment Act - 2007, Regulation on Occupational Health, Safety and Welfare - 2012, and other relevant national documents. All OHS items will remain as the property of the bidder upon completion of the project.</p>	L/S	1			
9	<p>Providing temporary living accommodation which includes bed room, kitchen, and toilet cum bathroom including proper water supply and electricity as per the drawing and temporary living accommodation standards. The accommodation facilities must be dismantled and cleaned upon the completion of project. All reusable materials of the accommodation facilities will remain as the property of the bidder upon completion of the project.</p>	L/S	1			
Total (B)						
Grand Total (A+B)						
In Words:						



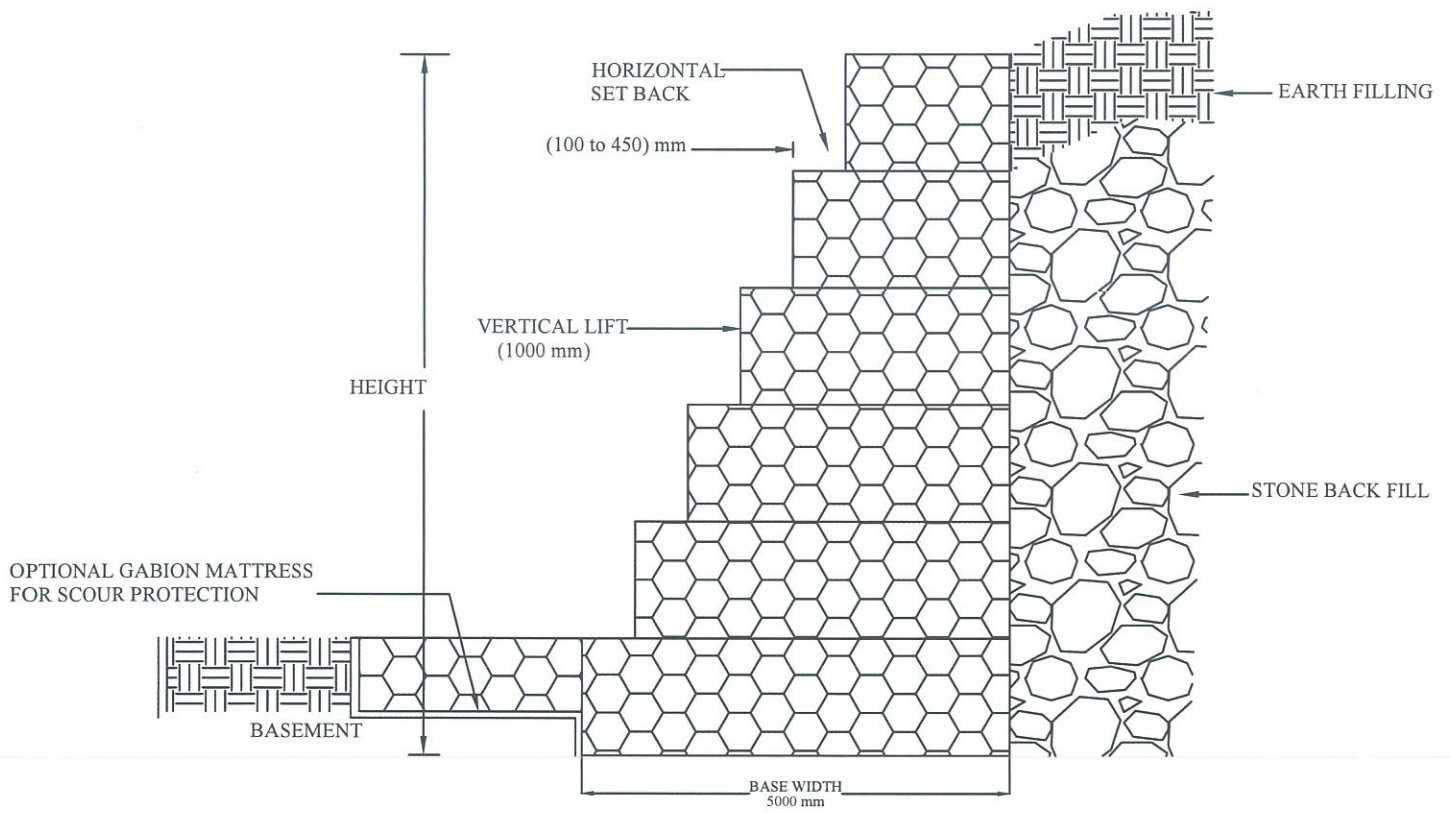
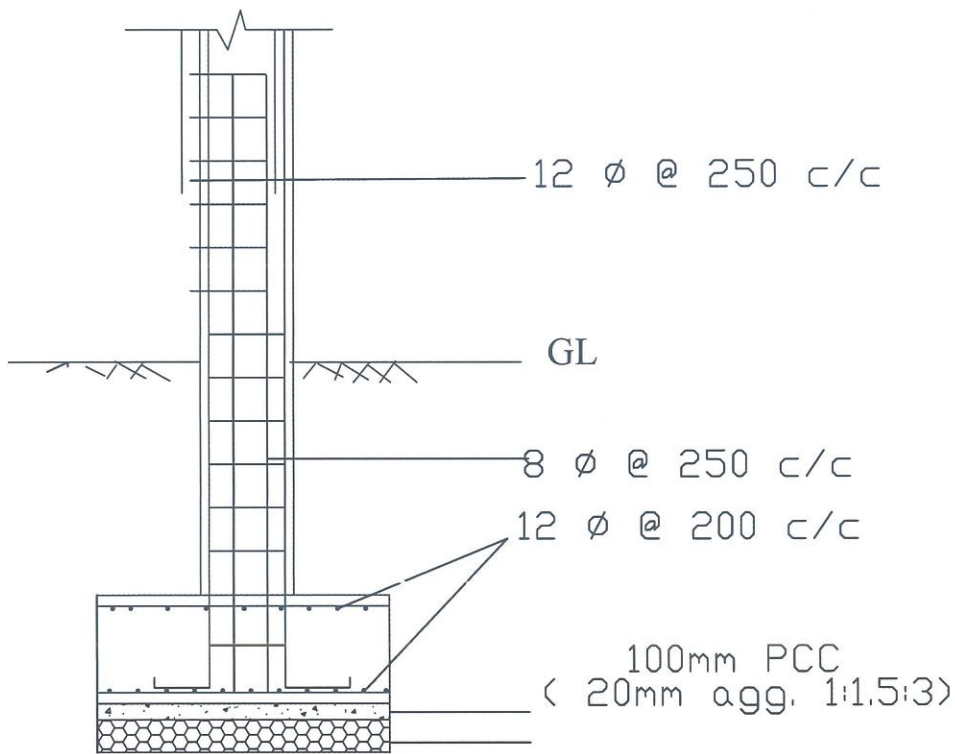
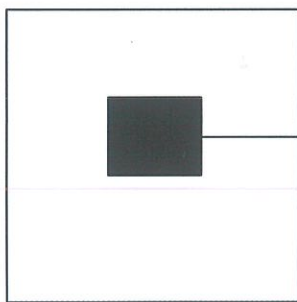

Fig:- TYPICAL DETAILS OF GABION WALL





FOOTING



Column
400 x 400mm

FOOTING
600 x 600 mm

Fig:- TYPICAL DETAILS OF
COLUMN

Note :

1. The Dimensions of the Columns and Footing may differ/varies as per the Site Conditions.

